

OMEGA330

TRANSVERSAL MOBILE STATION



This semi-trailer type station with transverse passage is designed for the inspection of light vehicles and heavy goods vehicles. Towed by a truck, it can be placed on the work area and does not require the mobilization of the towing vehicle.

TECHNICAL DATA & BASIC EQUIPMENT

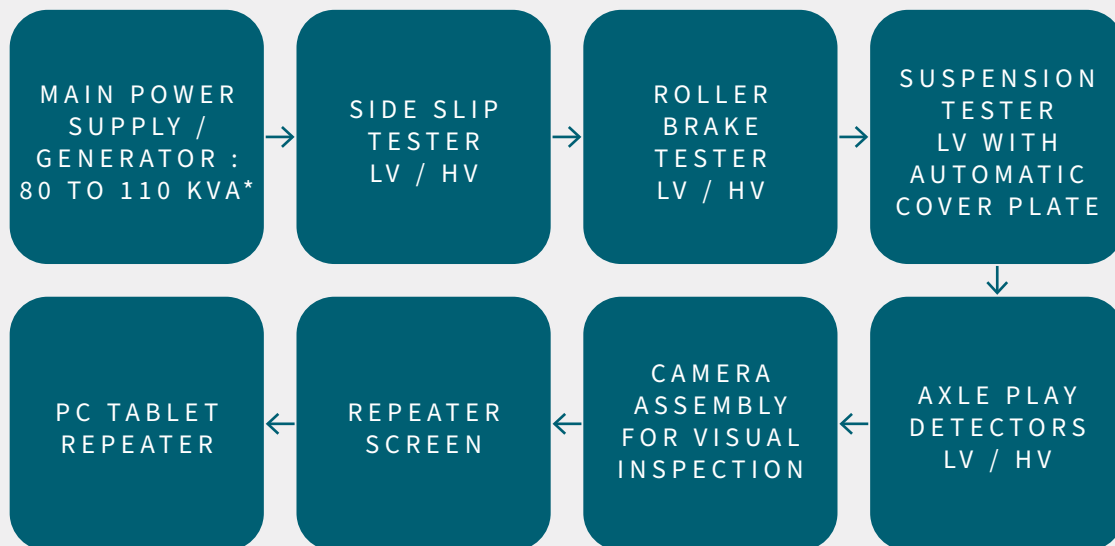

THIS STATION IS COMPOSED OF :

- A technical crossing area where the equipment necessary for technical inspection is located.
- A spacious office room to carry out the administrative tasks required for technical inspection
- A pop-up roof allowing the drive-by of vehicles with height
- All deployment functions are controlled hydraulically using a wired remote control.

FAST

Operational deployment in less than 15 minutes

FLEXIBILITY

Allows the control of light vehicles and heavy goods vehicles

ERGONOMIE

Spacious office room and independent technical room

ROBUST

Welded steel platform, double swan neck chassis

AUTONOMOUS

80 KVA generator set, associated with optional 48h tank

THIS STATION CAN BE EQUIPPED UPON YOUR REQUESTS AND OPTIONS

BASIC EQUIPMENT	3W	LV	HV
Main power supply / Generator 80 KVA		✓	✓
Roller brake tester			✓
Side slip tester			✓
axle play detectors			✓
Camera assembly for visual inspection		✓	✓
PC tablet repeater		✓	✓
Suspension tester		✓	
Repeater screen		✓	✓
OPTIONAL EQUIPMENT	3W	LV	HV
Headlight tester		✓	✓
Exhaust emission tester		✓	✓
Speedometer tester		✓	

DIMENSIONS ON ROAD

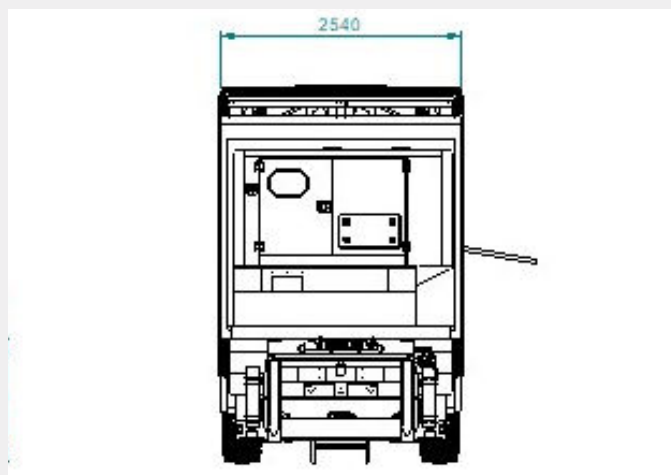
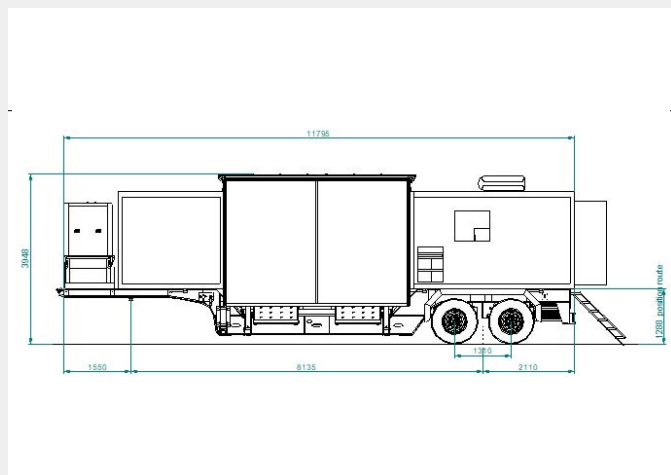

DIMENSIONS AT WORK

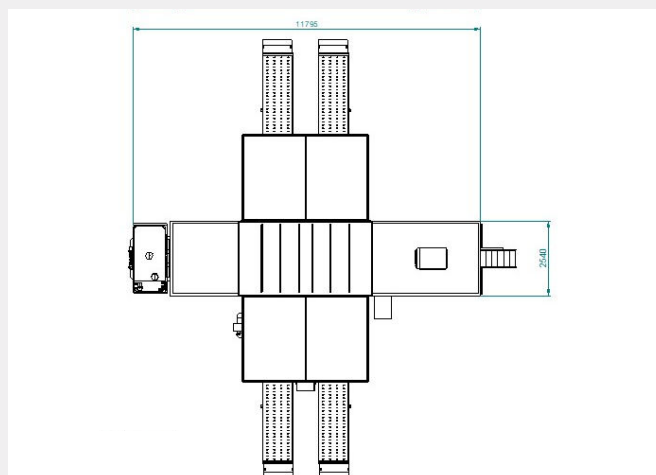
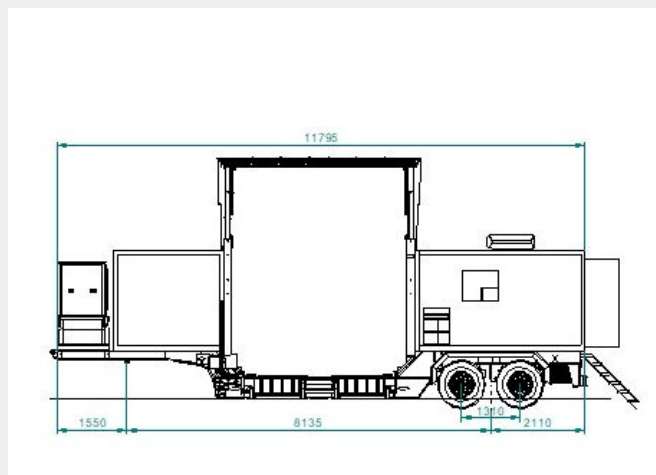

WEIGHT

33 000 kg