

# LIFTING TABLE

## ELECTRO-HYDRAULIC



### 4619316

#### LIFTING TABLE - 1200 KG

Ref. 4619316

This lifting table has been especially designed to easily and safely remove and install heavy batteries from electric vehicles, in conjunction with the use of a 2-post lift such as the Azur42AH.

The table is also suitable for vehicles with conventional thermal motors. The optional set of universal adaptors 4618041 makes it suitable for removing/installing heavy components from the underside of vehicles, such as complete motor/gearbox/axle assemblies, complete axles, complete exhaust systems, etc...

The lifting/lowering movement is motorized, with a remote control connected by wire, and the motion is electro-hydraulic.

The handling of the table throughout the workshop, is easily achieved with the pallet truck type orientable handle, which will raise the table few cm above its supports, and will allow for a very accurate positioning of the table under the load.

Large heavy duty rear wheels, long-lasting.

The lifting platform is:

- extendable, thanks to a sliding extension, lockable in every direction by the mean of low friction ergonomic turning nuts.

The table has been designed for a great physical stability, thus improving safety, even when loaded and fully raised.

Among other safety devices, the table offers a mechanical latching device, automatically operated.



## QUALITY

- High quality paint, with perfect finish.
- All technical components, such as hydraulic pack and E-Box.

## SAFETY

- Safety latching device, automatically and electrically operated.
- Remote control with an emergency stop button.
- All mechanical components are over-dimensioned, providing the table a great stability.

## VERSATILITY

- Full perforated platform (threaded holes), for attaching optional adapters and support pins, in such a way to have them positioned exactly where requested. Such threaded holes will also allow the use of specific supports from carmakers.
- Power supply is standard 230V single phase.
- 2 lifting speeds : first speed for fast approach and slow speed for precision positioning.
- The position of the platform is laterally adjustable (fine-tuning) to avoid the necessity to accurately position the table under the load to be supported/raised.
- Big size handle at the rear of the table, for easy handling.

CHARACTERISTICS	4619316	REMARKS
Lifting capacity	1200 kg	
Min. Height	800 mm	
Max. height	1810 mm	
Lifting platform length	1741 - 2066 mm	
Lifting platform width	800 mm	Platform is laterally adjustable (range: 20 mm)
Lifting platform tilting range	40 mm	
Lifting/lowering time	45 / 40 sec.	
Power supply	220V / 1 ph / 50 Hz	
Motor power	1,5 kW	
Nominal hydraulic pressure	160 bar	With pressure relief valve
Hydraulic oil capacity	4 litres	
Weight	560 kg	

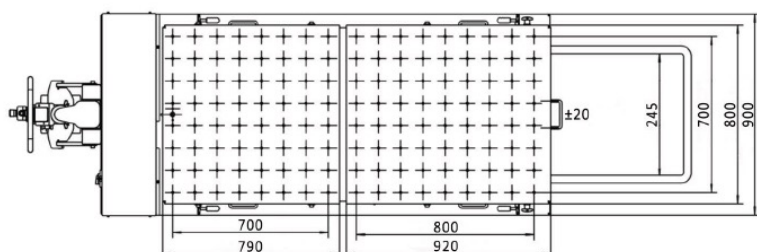
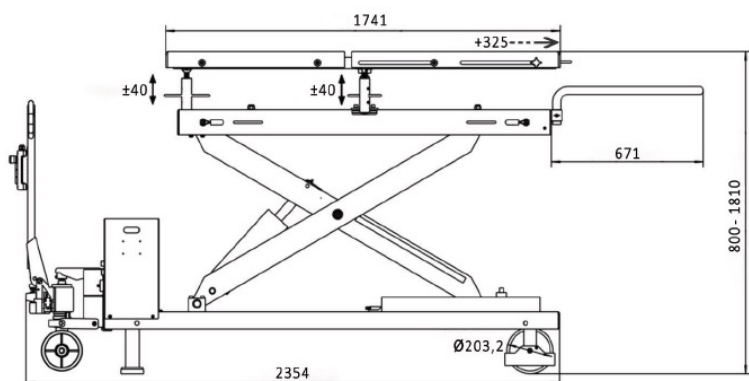

## ACCESSORY

### Ref. 4618041

Set, 8 universal adaptors, with oblong fixing hole for continuous and accurate position adjustment. The adaptor gets quickly and safely clamped onto the lifting platform, thanks to its thumb screw, to be hand tightened thumb screw.

Comprising :

- 4 adaptors with round pads, adjustable
- 4 adaptors with pin

